

HUR2x120-40

Soft Recovery Behaviour High-Performance Wide Temperature Range Ultra Fast Recovery Epitaxial Diodes

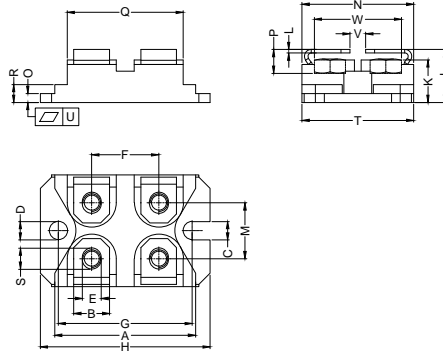

Dimensions SOT -227



Dim.	Millimeter		Dim.	Millimeter	
	Min.	Max.		Min.	Max.
A	31.30	31.65	M	12.00	13.00
B	7.80	8.40	N	25.15	25.65
C	4.00	4.30	O	1.95	2.15
D	∅4.00	∅4.30	P	5.60	6.60
E	4.00	4.30	Q	25.30	26.30
F	14.90	15.20	R	3.90	4.30
G	30.10	30.30	S	4.45	4.85
H	38.00	38.50	T	24.50	25.10
J	12.10	12.90	U	0.05	0.10
K	9.00	9.60	V	3.00	4.80
L	0.75	0.85	W	19.30	20.50

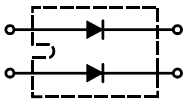

	V _{RSM} V	V _{RRM} V
HUR2x120-40	400	400



Symbol	Test Conditions	Maximum Ratings	Unit
I _{FRMS} I _{FAVM}	T _C =70°C; rectangular, d=0.5	120 120	A
I _{FSM}	T _{VJ} =45°C; t _p =10ms (50Hz), sine	1200	A
E _{AS}	T _{VJ} =25°C; non-repetitive; I _{AS} =4A; L=182uH	2	mJ
I _{AR}	V _A =1.5·V _R typ.; f=10kHz; repetitive	0.4	A
T _{VJ} T _{VJM} T _{stg}		-40...+150 150 -40...+150	°C
P _{tot}	T _C =25°C	250	W
V _{ISOL}	50/60Hz, RMS I _{ISOL} ≤1mA	2500	V~
M _d	mounting torque (M4) terminal connection torque (M4)	1.1-1.5/9-13 1.1-1.5/9-13	Nm/lb.in.
Weight	typical	30	g

Sirectifier®

HUR2x120-40

Soft Recovery Behaviour High-Performance Wide Temperature Range Ultra Fast Recovery Epitaxial Diodes

Symbol	Test Conditions	Characteristic Values		Unit
		typ.	max.	
I_R	$T_{VJ}=25^{\circ}\text{C}; V_R=V_{RRM}$ $T_{VJ}=150^{\circ}\text{C}; V_R=V_{RRM}$		0.01 0.50	mA
V_F	$I_F=120\text{A}; T_{VJ}=150^{\circ}\text{C}$ $T_{VJ}=25^{\circ}\text{C}$		1.06 1.24	V
R_{thJC} R_{thCH}	with heatsink compound	0.1	0.6	K/W
t_{tr}	$I_F=1\text{A}; -di/dt=400\text{A}/\mu\text{s}; V_R=30\text{V}; T_{VJ}=25^{\circ}\text{C}$	30		ns
I_{RM}	$V_R=100\text{V}; I_F=200\text{A}; -di_F/dt=100\text{A}/\mu\text{s}; T_{VJ}=100^{\circ}\text{C}$	5.5	6.8	A

FEATURES

- * International standard package SOT-227
- * Isolation voltage 2500 V~
- * 2 independent FRED in 1 package
- * Planar passivated chips
- * Very short recovery time
- * Extremely low switching losses
- * Low I_{RM} -values
- * Soft recovery behaviour
- * RoHS compliant

APPLICATIONS

- * Antiparallel diode for high frequency switching devices
- * Antisaturation diode
- * Snubber diode
- * Free wheeling diode in converters and motor control circuits
- * Rectifiers in switch mode power supplies (SMPS)
- * Inductive heating
- * Uninterruptible power supplies (UPS)
- * Ultrasonic cleaners and welders

ADVANTAGES

- * Avalanche voltage rated for reliable operation
- * Soft reverse recovery for low EMI/RFI
- * Low I_{RM} reduces:
 - Power dissipation within the diode
 - Turn-on loss in the commutating switch

ORDERING INFORMATION

Part Number	Package	Shipping	Marking Code
HUR2x120-40	SOT-227	10pcs / Tube	HUR2x120-40

HUR2x120-40

Soft Recovery Behaviour High-Performance Wide Temperature Range Ultra Fast Recovery Epitaxial Diodes

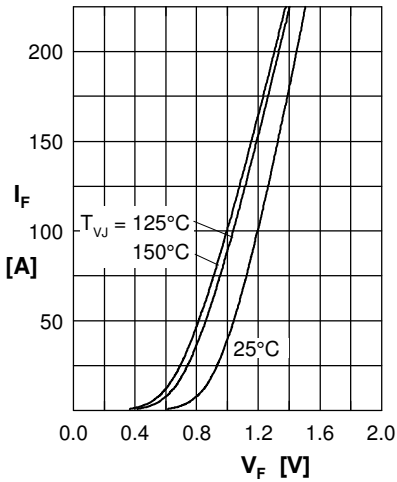

Fig. 1 Forward current I_F vs. V_F

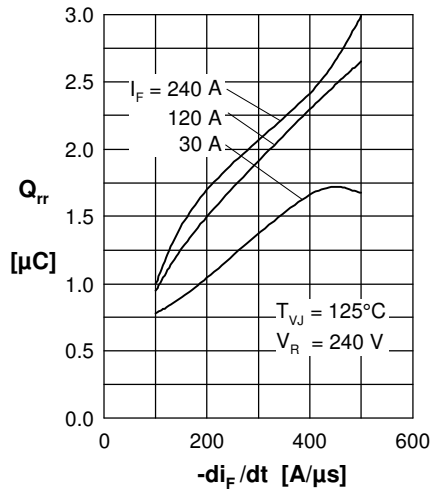

Fig. 2 Typ. reverse recovery charge Q_{rr} vs. $-di_F/dt$

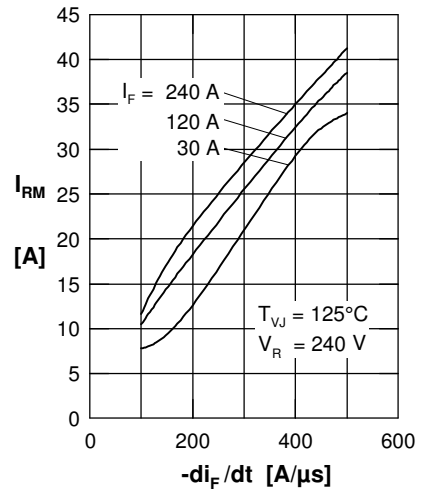

Fig. 3 Typ. reverse recovery current I_{RM} vs. $-di_F/dt$

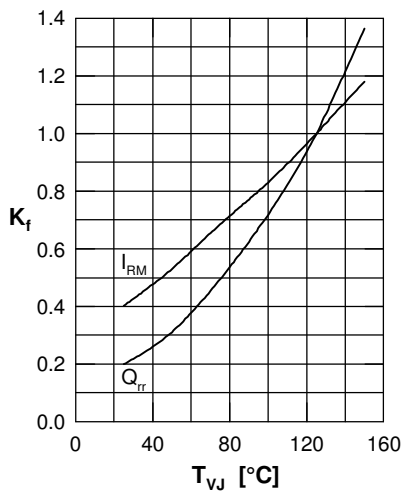

Fig. 4 Typ. dynamic parameters Q_{rr} , I_{RM} vs. T_{VJ}

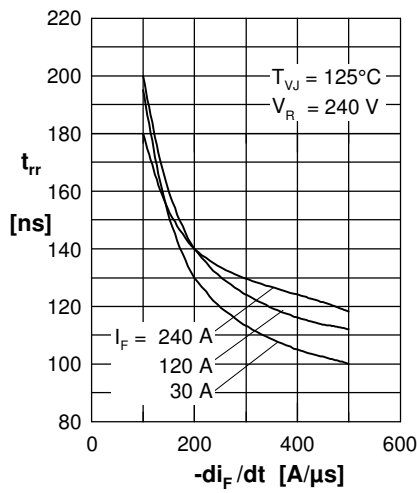

Fig. 5 Typ. reverse recovery time t_{rr} vs. $-di_F/dt$

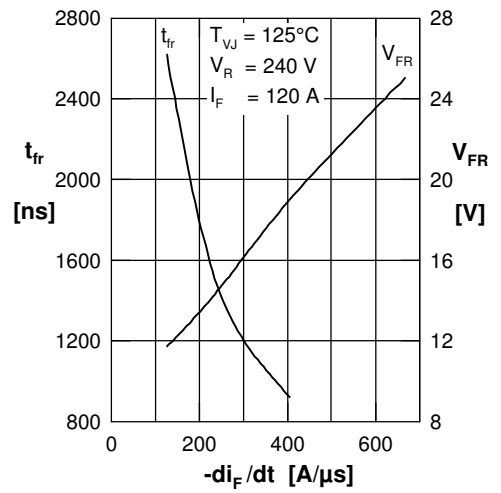

Fig. 6 Typ. forward recovery voltage V_{FR} & t_{fr} vs. di_F/dt

HUR2x120-40

Soft Recovery Behaviour High-Performance Wide Temperature Range Ultra Fast Recovery Epitaxial Diodes

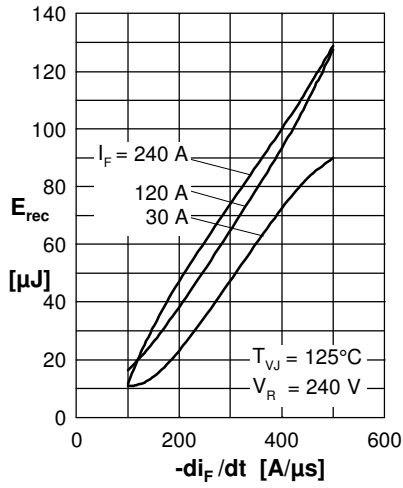

Fig. 7 Typ. recovery energy E_{rec} vs. $-di_F/dt$

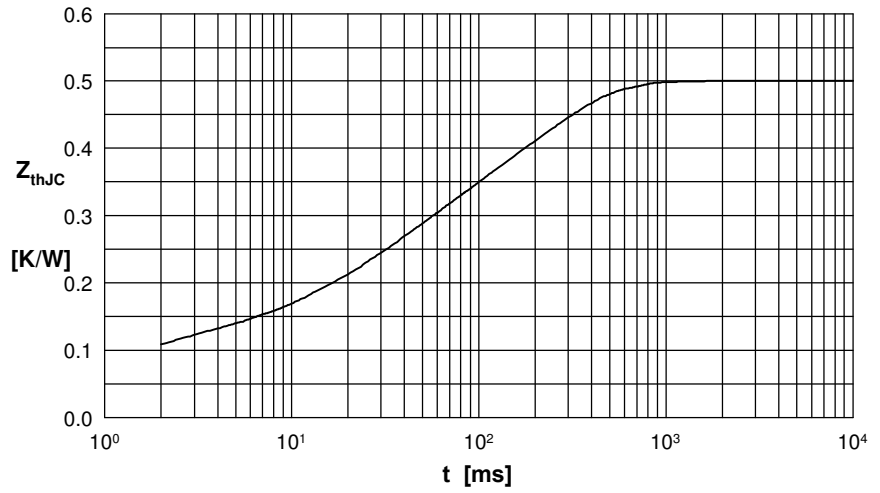

Fig. 8 Transient thermal impedance junction to case